

BV SERIES

High Purity Ball Valves

CARTEN
Ultra High Purity Valves



PRODUCT APPLICATIONS

The Carten BV series stainless steel ball valves are intended for clean dry air (CDA), utility nitrogen, house nitrogen, instrument air (IA) and other non process distribution services. The BV series is the first choice in the semiconductor industry where containment, purity and integrity are critical to the customers needs. Applications include:

- ▶ High purity gas service
- ▶ CDA, UN2, HN2, IA systems
- ▶ In line isolation valve, duplex lateral and uniplex lateral configurations

PRODUCT FEATURES

- ▶ 316L Barstock Body Flanges Design for High Integrity
- ▶ Standard Operating Pressure of 375psi (25bar).
- ▶ Operating Temperature Range -17°C (0°F) to 82.2°C (180°F)
- ▶ Outboard Leak Tested, Rated to 1×10^{-7} at 375psi
- ▶ Flash Electropolished on the Internal Wetted Area
- ▶ Purged and Final packaged in CLASS 10 Cleanroom. Double-bag packaging with N₂ Gas supplied from liquid source
- ▶ Available from 1/4" to 6" line sizes

CONSTRUCTION MATERIALS

- ▶ 316L St. St. Barstock Body & Flanges (Items 2 & 3)
- ▶ Virgin PTFE Seats & Seals (standard) (Items 4 & 5)
- ▶ 316L Electropolished Tube Stubs (Item 1)

BV SERIES - Cut Section View

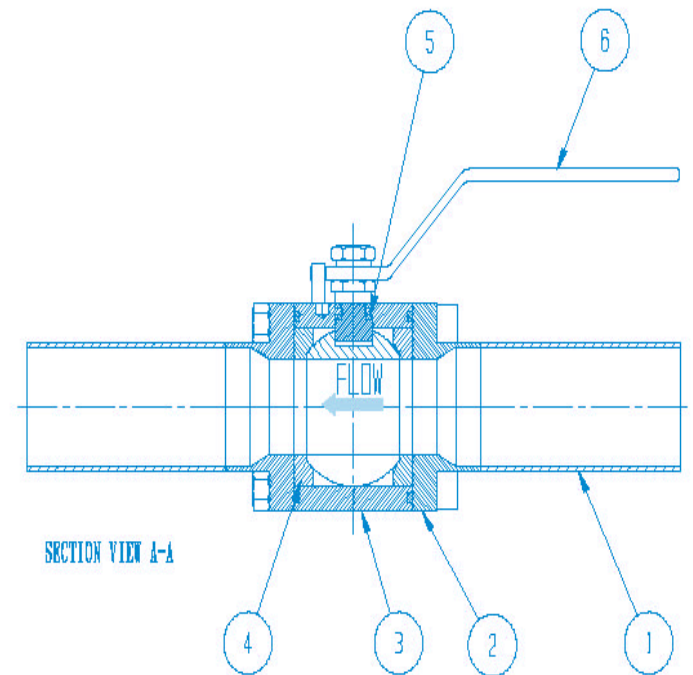

BV SERIES - Technical Data

CONSTRUCTION MATERIAL	Wetted Areas	316L Stainless Steel, PTFE
	Non-Wetted Areas	Stainless Steel
TEMPERATURE RANGE	BV Series	-17°C to 82°C (-0°F to 180°F)
FLOW COEFFICIENT	BV250	1.00
	BV375	2.00
	BV500	5.00
	BV750	13.00
	BV1000	32.00
	BV1500	82.00
	BV2000	111.00
	BV2500	241.00
	BV3000	319.00
	BV4000	580.00
BV6000	812.00	
LINE PRESSURE	BV Series	375psi (25bar) Standard

LEAK RATES	Across The Seat	1×10^{-7} scc/s He Max. at 375psi
	Outboard	1×10^{-7} scc/s He Max. at 375psi
CLEANLINESS/ PACKAGING	Assembled and tested in CLASS 10 cleanroom. Double-bag packaging (2 mil nylon inner bag, 6 mil polyethylene outer bag) with N ₂ gas environment supplied from liquid source.	
STANDARD FINISH	Electropolished to 30Ra (0.80 µm) on all wetted surfaces	
OPTIONS	Surface Finish – 15Ra, 25Ra, etc. High Pressure Applications – 3000psi Delrin Seats & Seals Pneumatic Actuation Compression End Connections from 1/4" through to 1" Duplex and Uniplex Configurations Available	

Specifications subject to change without notice

Component Selection

The total system design must be considered when selecting a valve to ensure performance. Valve application, materials compatibility, installation, operation and maintenance are the responsibility of the system design engineer.

NOTE 1: Dimensional drawings shown are for reference only. Please contact the manufacturer for customer drawings showing updated dimensions. Also contact the manufacturer for the various configurations available.