

ultra high purity

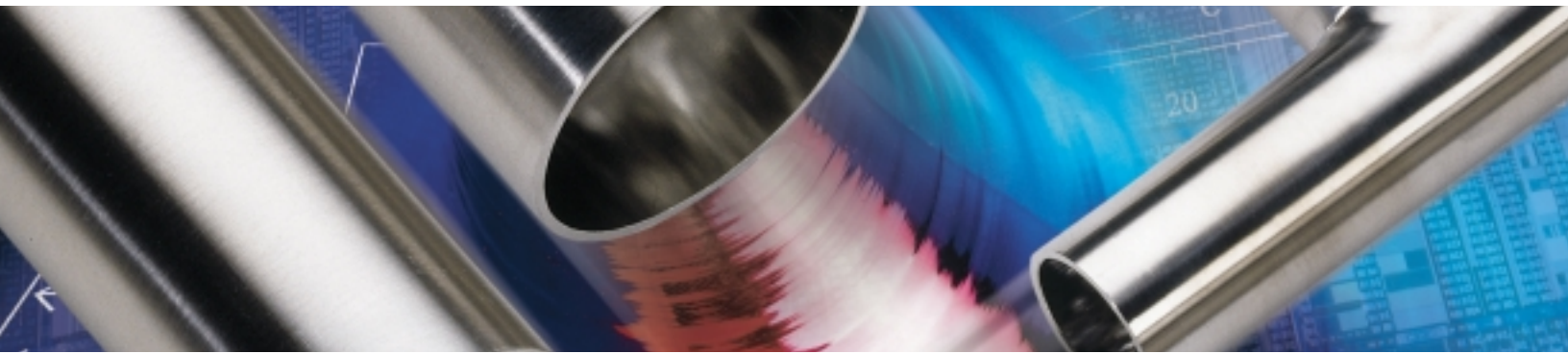

tubing and fittings dimensional specifications

Contents	Page
part description system	1
tubing/coaxial specifications	2
90° elbow (2WW)	3
45° elbow (3WW)	4
reducing tee (7RWWW)	5-6
concentric reducer (31WW)	7
equal tee (7WWW)	8
end cap (16W)	8
coaxial 45° elbow (X3WW)	9
coaxial 90° elbow (X2WW)	9
coaxial sleeve coupling (XSC)	10
coaxial termination (XTM)	10
coaxial starter piece (XSP)	10
coaxial equal tee (X7WWW)	11
coaxial purge tee (XPT)	11
coaxial reducing tee (X7RWWW)	12
product specifications	13-14

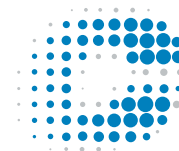

CARDINAL
UHP

an O'BRIEN company

part description system

part description system

Cap Color Code:

Product Specification
descriptions p13

- Tech 5 (white)
- Tech 10 (orange)
- Tech 20 (green)
- Tech 25 (black)
- Tech 50 (blue)
- Tech 100 (red)
- Tech TG22 (yellow)

Single Wall Tube Example:

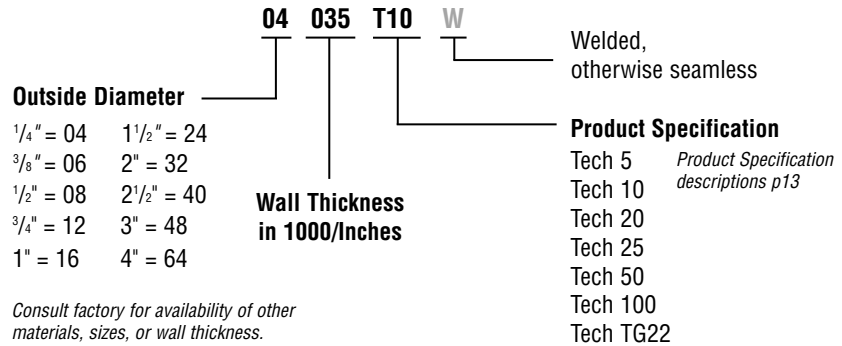

Coaxial Tube Example:

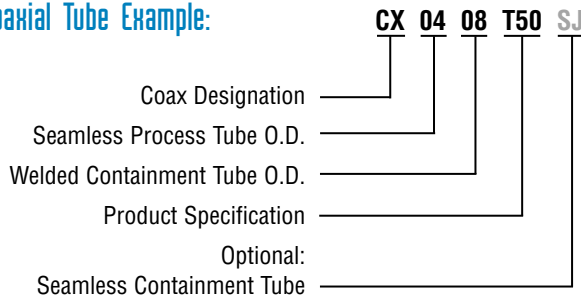

Fitting Example:

- 90° Elbow = 2WW
- 45° Elbow = 3WW
- Equal Tee = 7WWWW
- End Cap = 16W

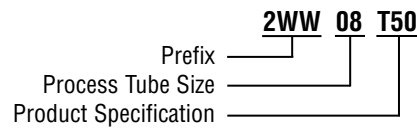

- Concentric Reducer = 31WW
- Reducing Tee = 7RWWWW
- Coaxial Reducing Tee = X7RWWWW

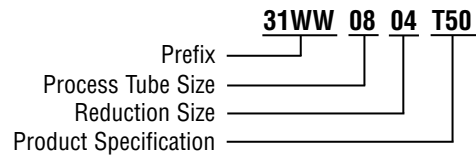

- Coaxial 90° Elbow = X2WW
- Coaxial 45° Elbow = X3WW
- Coaxial Equal Tee = X7WWWW
- Coaxial Starter Piece = XSP
- Purge Tee w/VCR = XPT
- Purge Tee w/Two VCR = XPTV

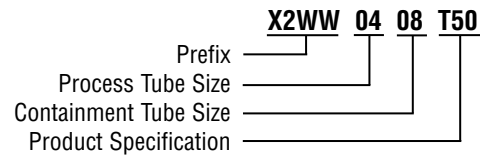

- Coaxial Sleeve Coupling* = XSC
- Coaxial Termination* = XTM

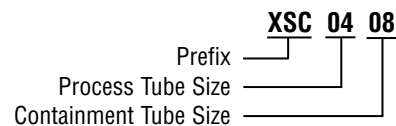

*These components are manufactured to containment tube specifications and do not have a specification suffix.

tubing specifications

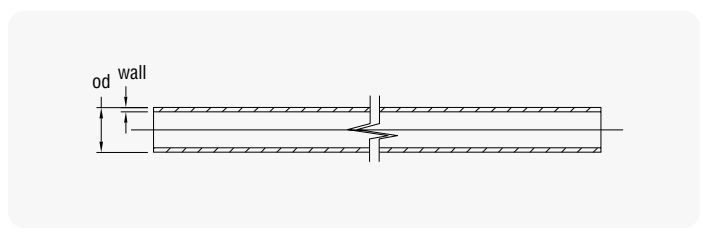

To complete part number add product specification.
Example: 04035T50

part no.	material	dimensions				product specifications						
		od	wall	lb/ft	kg/m	5	10	20	25	50	100	TG22
04035T_	316L SS SMLS	.250	.035	.080	.180	●	●	●	●	●	●	
04035TG22	Hastelloy® C22 SMLS	.250	.035	.080	.180							●
06035T_	316L SS SMLS	.375	.035	.130	.290	●	●	●	●	●	●	
06035TG22	Hastelloy C22 SMLS	.375	.035	.130	.290							●
08049T_	316L SS SMLS	.500	.049	.240	.530	●	●	●	●	●		
08049TG22	Hastelloy C22 SMLS	.500	.049	.240	.530							●
12065T_	316L SS SMLS	.750	.065	.480	1.06	●	●	●	●	●		
16065T_W	316L SS WLD	1.00	.065	.650	1.43	●	●	●	●	●		
16065T_	316L SS SMLS	1.00	.065	.650	1.43			●	●	●		
24065T_W	316L SS WLD	1.50	.065	1.00	2.21	●	●	●	●	●		
24065T_	316L SS SMLS	1.50	.065	1.00	2.21			●	●	●		
32065T_W	316L SS WLD	2.00	.065	1.34	2.95	●	●	●	●	●		
32065T_	316L SS SMLS	2.00	.065	1.34	2.95			●	●	●		
48065T_W	316L SS WLD	3.00	.065	2.03	4.48	●	●	●	●	●		
64065T_W	316L SS WLD	4.00	.083	3.47	7.65	●	●	●	●	●		

Consult factory for availability of other materials, sizes, or wall thickness.

coaxial tubing specifications

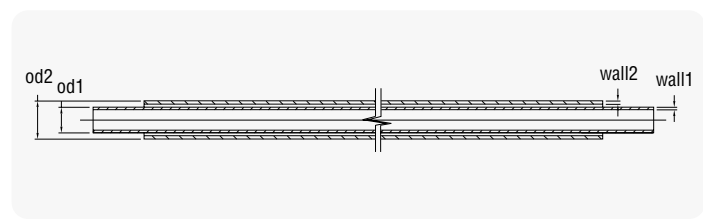

To complete part number add product specification.
Example: CX0408T50

part no.	process tube	dimensions						product specifications					
		process od1	wall1	contain od2	wall2	lb/ft	kg/m	10	20	25	50	100	TG22
CX0408T_	316L SS SMLS	.250	.035	.500	.049	.320	.706	●	●	●	●	●	
CX0408TG22	Hastelloy® C22 SMLS	.250	.035	.500	.049	.320	.706						●
CX0610T_	316L SS SMLS	.375	.035	.625	.049	.490	1.08	●	●	●	●	●	
CX0610TG22	Hastelloy C22 SMLS	.375	.035	.625	.049	.490	1.08						●
CX0812T_	316L SS SMLS	.500	.049	.750	.065	.720	1.59	●	●	●	●	●	
CX0812TG22	Hastelloy C22 SMLS	.500	.049	.750	.065	.720	1.59						●
CX1216T_	316L SS SMLS	.750	.065	1.00	.065	1.13	2.49	●	●	●	●		
CX1620T_	316L SS SMLS	1.00	.265	1.25	.065	1.52	3.35	●	●	●	●		

Consult factory for availability of coaxial tubing with seamless containment tube.

90° elbow 2WW

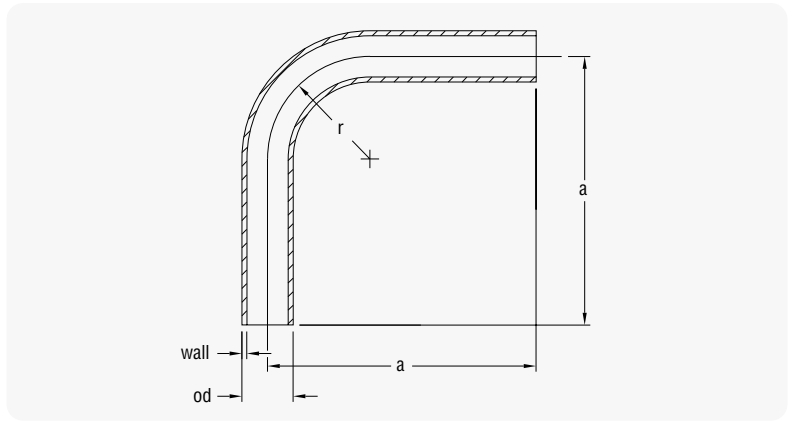

To complete part number add product specification.
Example: 2WW04T50

part no.	material	dimensions						product specifications						
		od	wall	a	r	a mm	r mm	5	10	20	25	50	100	TG22
2WW04T_	316L SS SMLS	.250	.035	2.06	.560	52	14	●	●	●	●	●	●	
2WW04TG22	Hastelloy® C22 SMLS	.250	.035	2.06	.560	52	14							●
2WW06T_	316L SS SMLS	.375	.035	2.62	.560	67	14	●	●	●	●	●	●	
2WW06TG22	Hastelloy C22 SMLS	.375	.035	2.62	.560	67	14							●
2WW08T_	316L SS SMLS	.500	.049	2.62	.750	67	19	●	●	●	●	●	●	
2WW08TG22	Hastelloy C22 SMLS	.500	.049	2.62	.750	67	19							●
2WW12T_	316L SS SMLS	.750	.065	2.62	1.12	67	28	●	●	●	●	●		
2WW16T_W	316L SS WLD	1.00	.065	4.00	1.50	102	38	●	●	●	●	●		
2WW16T_	316L SS SMLS	1.00	.065	4.00	1.50	102	38	●	●	●	●	●		
2WW24T_W	316L SS WLD	1.50	.065	3.75	2.25	95	57	●	●	●	●	●		
2WW24T_	316L SS SMLS	1.50	.065	3.75	2.25	95	57	●	●	●	●	●		
2WW32T_W	316L SS WLD	2.00	.065	4.75	3.00	121	76	●	●	●	●	●		
2WW32T_	316L SS SMLS	2.00	.065	4.75	3.00	121	76	●	●	●	●	●		
2WW48T_W	316L SS WLD	3.00	.065	6.25	4.50	159	114	●	●	●	●	●		
2WW64T_W	316L SS WLD	4.00	.083	8.00	6.00	203	152	●	●	●	●	●		

45° elbow 3WW

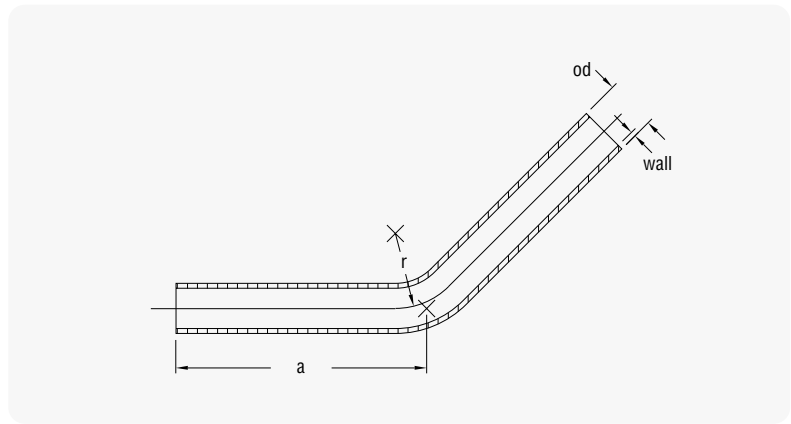

To complete part number add product specification.
Example: 3WW04T50

part no.	material	dimensions						product specifications						
		od	wall	a	r	a mm	r mm	5	10	20	25	50	100	T622
3WW04T_	316L SS SMLS	.250	.035	1.10	.560	28	14	●	●	●	●	●	●	
3WW04TG22	Hastelloy® C22 SMLS	.250	.035	1.10	.560	51	14							●
3WW06T_	316L SS SMLS	.375	.035	2.00	.560	51	14	●	●	●	●	●	●	
3WW06TG22	Hastelloy C22 SMLS	.375	.035	2.00	.560	51	14							●
3WW08T_	316L SS SMLS	.500	.049	2.50	.750	64	19	●	●	●	●	●	●	
3WW08TG22	Hastelloy C22 SMLS	.500	.049	2.50	.750	64	19							●
3WW12T_	316L SS SMLS	.750	.065	2.50	1.12	64	28	●	●	●	●	●		
3WW16T_W	316L SS WLD	1.00	.065	3.12	1.50	79	38	●	●	●	●	●		
3WW16T_	316L SS SMLS	1.00	.065	3.12	1.50	79	38	●	●	●	●	●		
3WW24T_W	316L SS WLD	1.50	.065	2.50	2.25	64	57	●	●	●	●	●		
3WW24T_	316L SS SMLS	1.50	.065	2.50	2.25	64	57	●	●	●	●	●		
3WW32T_W	316L SS WLD	2.00	.065	3.00	3.00	76	76	●	●	●	●	●		
3WW32T_	316L SS SMLS	2.00	.065	3.00	3.00	76	76	●	●	●	●	●		
3WW48T_W	316L SS WLD	3.00	.065	3.625	4.50	92	114	●	●	●	●	●		
3WW64T_W	316L SS WLD	4.00	.083	4.50	6.00	114	152	●	●	●	●	●		

reducing tee
7RWWW

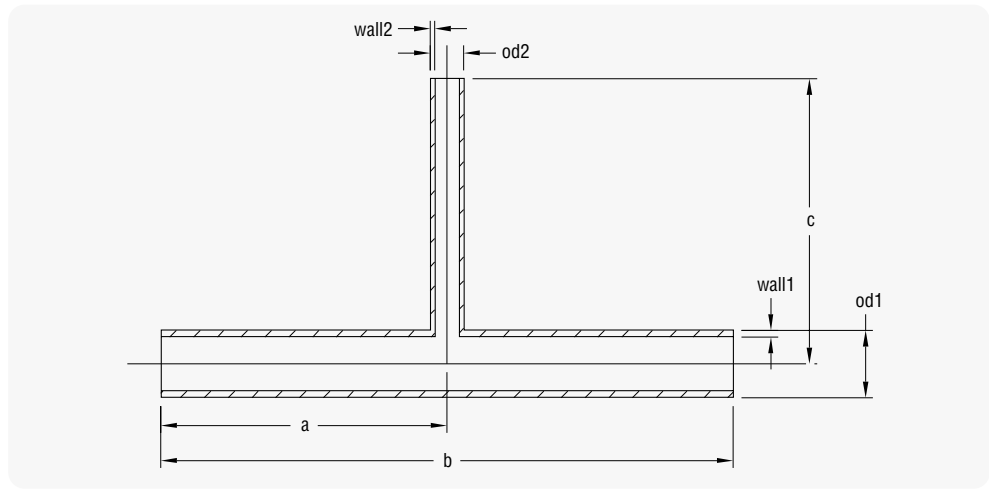

To complete part number add product specification.
Example: 7RWWW0604T50

part no.	material	dimensions										product specifications						
		od1	od2	wall1	wall2	a	b	c	a mm	b mm	c mm	5	10	20	25	50	100	T622
7RWWW0604T	316L SS SMLS	.375	.250	.035	.035	1.75	3.50	1.75	45	89	45	●	●	●	●	●	●	
7RWWW0604TG22	Hastelloy® C22 SMLS	.375	.250	.035	.035	1.75	3.50	1.75	45	89	45							●
7RWWW0804T	316L SS SMLS	.500	.250	.049	.035	2.12	4.25	2.12	54	108	54	●	●	●	●	●	●	
7RWWW0804TG22	Hastelloy C22 SMLS	.500	.250	.049	.035	2.12	4.25	2.12	54	108	54							●
7RWWW0806T	316L SS SMLS	.500	.375	.049	.035	2.12	4.25	2.12	54	108	54	●	●	●	●	●	●	
7RWWW0806TG22	Hastelloy C22 SMLS	.500	.375	.049	.035	2.12	4.25	2.12	54	108	54							●
7RWWW1204T	316L SS SMLS	.750	.250	.065	.035	2.12	4.25	2.12	54	108	54	●	●	●	●	●		
7RWWW1206T	316L SS SMLS	.750	.375	.065	.035	2.12	4.25	2.12	54	108	54	●	●	●	●	●		
7RWWW1208T	316L SS SMLS	.750	.500	.065	.049	2.12	4.25	2.12	54	108	54	●	●	●	●	●		
7RWWW1604T	316L SS SMLS	1.00	.250	.065	.035	2.50	5.00	2.50	64	127	64	●	●	●	●	●		
7RWWW1606T	316L SS SMLS	1.00	.375	.065	.035	2.50	5.00	2.50	64	127	64	●	●	●	●	●		
7RWWW1608T	316L SS SMLS	1.00	.500	.065	.049	2.50	5.00	2.50	64	127	64	●	●	●	●	●		
7RWWW1612T	316L SS SMLS	1.00	.750	.065	.065	2.50	5.00	2.50	64	127	64	●	●	●	●	●		
7RWWW2404T_W	316L SS WLD	1.50	.250	.065	.035	2.375	4.75	2.375	60	121	60	●	●	●	●	●		
7RWWW2404T	316L SS SMLS	1.50	.250	.065	.035	2.375	4.75	2.375	60	121	60	●	●	●	●	●		
7RWWW2406T_W	316L SS WLD	1.50	.375	.065	.035	2.375	4.75	2.375	60	121	60	●	●	●	●	●		
7RWWW2406T	316L SS SMLS	1.50	.375	.065	.035	2.375	4.75	2.375	60	121	60	●	●	●	●	●		
7RWWW2408T_W	316L SS WLD	1.50	.500	.065	.049	2.375	4.75	2.375	60	121	60	●	●	●	●	●		
7RWWW2408T	316L SS SMLS	1.50	.500	.065	.049	2.375	4.75	2.375	60	121	60	●	●	●	●	●		
7RWWW2412T_W	316L SS WLD	1.50	.750	.065	.065	2.375	4.75	2.375	60	121	60	●	●	●	●	●		
7RWWW2412T	316L SS SMLS	1.50	.750	.065	.065	2.375	4.75	2.375	60	121	60	●	●	●	●	●		
7RWWW2416T_W	316L SS WLD	1.50	1.00	.065	.065	2.375	4.75	2.375	60	121	60	●	●	●	●	●		
7RWWW2416T	316L SS SMLS	1.50	1.00	.065	.065	2.375	4.75	2.375	60	121	60	●	●	●	●	●		
7RWWW3204T_W	316L SS WLD	2.00	.250	.065	.035	2.875	5.75	2.875	83	165	83	●	●	●	●	●		
7RWWW3204T	316L SS SMLS	2.00	.250	.065	.035	2.875	5.75	2.875	83	165	83	●	●	●	●	●		

continued next page

reducing tee (cont.)
7RWWW

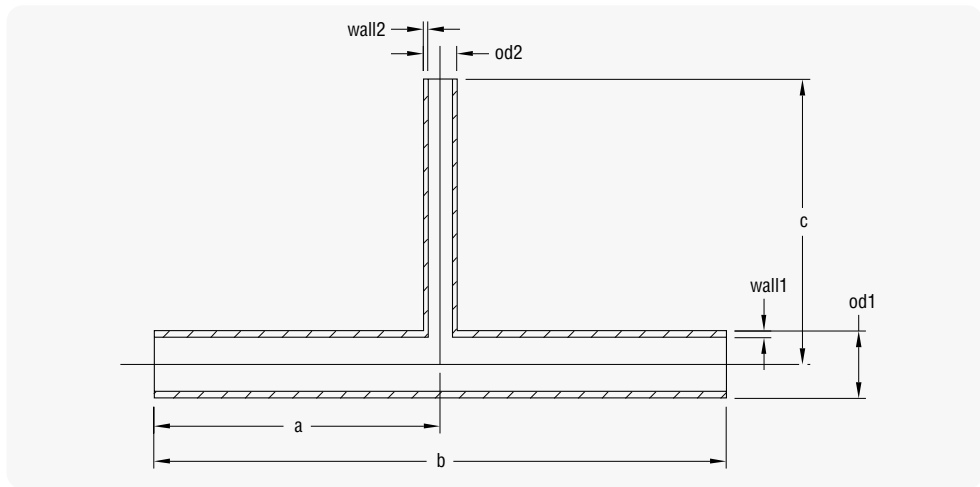

To complete part number add product specification.
Example: 7RWWW0604T50

part no.	material	dimensions										product specifications						
		od1	od2	wall1	wall2	a	b	c	a mm	b mm	c mm	5	10	20	25	50	100	T622
7RWWW3206T_W	316L SS WLD	2.00	.375	.065	.035	2.875	5.75	2.875	83	165	83	●	●	●	●	●		
7RWWW3206T_	316L SS SMLS	2.00	.375	.065	.035	2.875	5.75	2.875	83	165	83	●	●	●	●	●		
7RWWW3208T_W	316L SS WLD	2.00	.500	.065	.049	2.875	5.75	2.625	73	146	67	●	●	●	●	●		
7RWWW3208T_	316L SS SMLS	2.00	.500	.065	.049	2.875	5.75	2.625	73	146	67	●	●	●	●	●		
7RWWW3212T_W	316L SS WLD	2.00	.750	.065	.065	2.875	5.75	2.625	73	146	67	●	●	●	●	●		
7RWWW3212T_	316L SS SMLS	2.00	.750	.065	.065	2.875	5.75	2.625	73	146	67	●	●	●	●	●		
7RWWW3216T_W	316L SS WLD	2.00	1.00	.065	.065	2.875	5.75	2.625	73	146	67	●	●	●	●	●		
7RWWW3216T_	316L SS SMLS	2.00	1.00	.065	.065	2.875	5.75	2.625	73	146	67	●	●	●	●	●		
7RWWW3224T_W	316L SS WLD	2.00	1.50	.065	.065	2.875	5.75	2.625	73	146	67	●	●	●	●	●		
7RWWW3224T_	316L SS SMLS	2.00	1.50	.065	.065	2.875	5.75	2.625	73	146	67	●	●	●	●	●		
7RWWW4804T_W	316L SS WLD	3.00	.250	.065	.035	3.375	6.75	3.125	86	172	79	●	●	●	●	●		
7RWWW4806T_W	316L SS WLD	3.00	.375	.065	.035	3.375	6.75	3.125	86	172	79	●	●	●	●	●		
7RWWW4808T_W	316L SS WLD	3.00	.500	.065	.049	3.375	6.75	3.125	86	172	79	●	●	●	●	●		
7RWWW4812T_W	316L SS WLD	3.00	.750	.065	.065	3.375	6.75	3.125	86	172	79	●	●	●	●	●		
7RWWW4816T_W	316L SS WLD	3.00	1.00	.065	.065	3.375	6.75	3.125	86	172	79	●	●	●	●	●		
7RWWW4824T_W	316L SS WLD	3.00	1.50	.065	.065	3.375	6.75	3.125	86	172	79	●	●	●	●	●		
7RWWW4832T_W	316L SS WLD	3.00	2.00	.065	.065	3.375	6.75	3.125	86	172	79	●	●	●	●	●		
7RWWW6404T_W	316L SS WLD	4.00	.250	.083	.035	4.125	8.25	3.625	105	210	92	●	●	●	●	●		
7RWWW6406T_W	316L SS WLD	4.00	.375	.083	.035	4.125	8.25	3.625	105	210	92	●	●	●	●	●		
7RWWW6408T_W	316L SS WLD	4.00	.500	.083	.049	4.125	8.25	3.625	105	210	92	●	●	●	●	●		
7RWWW6412T_W	316L SS WLD	4.00	.750	.083	.065	4.125	8.25	3.625	105	210	92	●	●	●	●	●		
7RWWW6416T_W	316L SS WLD	4.00	1.00	.083	.065	4.125	8.25	3.625	105	210	92	●	●	●	●	●		
7RWWW6424T_W	316L SS WLD	4.00	1.50	.083	.065	4.125	8.25	3.625	105	210	92	●	●	●	●	●		
7RWWW6432T_W	316L SS WLD	4.00	2.00	.083	.065	4.125	8.25	3.875	105	210	98	●	●	●	●	●		
7RWWW6448T_W	316L SS WLD	4.00	3.00	.083	.065	4.125	8.25	3.875	105	210	98	●	●	●	●	●		

Consult factory for availability of other materials, sizes, or wall thickness.

concentric reducer 31WW

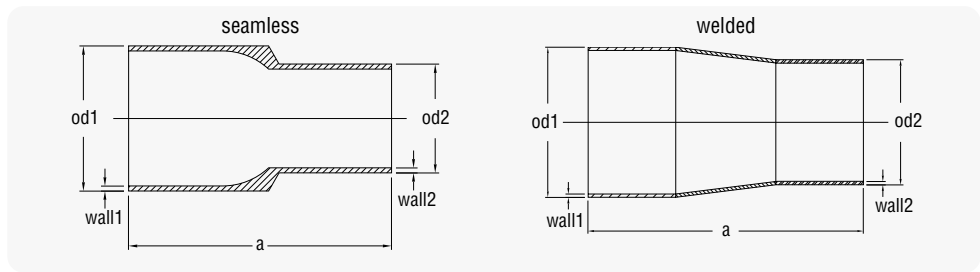

To complete part number add product specification.

Example: 31WW0604T50

part no.	material	dimensions						product specifications						
		od1	od2	wall1	wall2	a	a mm	5	10	20	25	50	100	T622
31WW0604T_	316L SS SMLS	.375	.250	.035	.035	2.75	70	●	●	●	●	●	●	
31WW0604TG22	Hastelloy® C22 SMLS	.375	.250	.035	.035	2.75	70							●
31WW0804T_	316L SS SMLS	.500	.250	.049	.035	2.75	70	●	●	●	●	●	●	
31WW0804TG22	Hastelloy C22 SMLS	.500	.250	.049	.035	2.75	70							●
31WW0806T_	316L SS SMLS	.500	.375	.049	.035	2.75	70	●	●	●	●	●	●	
31WW0806TG22	Hastelloy C22 SMLS	.500	.375	.049	.035	2.75	70							●
31WW1204T_	316L SS SMLS	.750	.250	.065	.035	2.75	70	●	●	●	●	●		
31WW1206T_	316L SS SMLS	.750	.375	.065	.035	2.75	70	●	●	●	●	●		
31WW1208T_	316L SS SMLS	.750	.500	.065	.049	2.75	70	●	●	●	●	●		
31WW1604T_	316L SS SMLS	1.00	.250	.065	.035	3.00	76	●	●	●	●	●		
31WW1606T_	316L SS SMLS	1.00	.375	.065	.035	3.00	76	●	●	●	●	●		
31WW1608T_	316L SS SMLS	1.00	.500	.065	.049	3.00	76	●	●	●	●	●		
31WW1612T_	316L SS SMLS	1.00	.750	.065	.065	3.00	76	●	●	●	●	●		
31WW2404T_	316L SS SMLS	1.50	.250	.065	.035	5.50	140	●	●	●	●	●		
31WW2406T_	316L SS SMLS	1.50	.375	.065	.035	5.50	140	●	●	●	●	●		
31WW2408T_	316L SS SMLS	1.50	.500	.065	.049	5.50	140	●	●	●	●	●		
31WW2412T_	316L SS SMLS	1.50	.750	.065	.065	5.00	127	●	●	●	●	●		
31WW2412T_W	316L SS WLD	1.50	.750	.065	.065	5.00	127	●	●	●	●	●		
31WW2416T_	316L SS SMLS	1.50	1.00	.065	.065	5.00	127	●	●	●	●	●		
31WW2416T_W	316L SS WLD	1.50	1.00	.065	.065	5.00	127	●	●	●	●	●		
31WW3204T_	316L SS SMLS	2.00	.250	.065	.035	7.75	197	●	●	●	●	●		
31WW3206T_	316L SS SMLS	2.00	.375	.065	.035	7.75	197	●	●	●	●	●		
31WW3208T_	316L SS SMLS	2.00	.500	.065	.049	7.75	197	●	●	●	●	●		
31WW3212T_	316L SS SMLS	2.00	.750	.065	.065	7.25	184	●	●	●	●	●		
31WW3212T_W	316L SS WLD	2.00	.750	.065	.065	7.25	184	●	●	●	●	●		
31WW3216T_	316L SS SMLS	2.00	1.00	.065	.065	7.25	184	●	●	●	●	●		
31WW3216T_W	316L SS WLD	2.00	1.00	.065	.065	7.25	184	●	●	●	●	●		
31WW3224T_	316L SS SMLS	2.00	1.50	.065	.065	5.25	133	●	●	●	●	●		
31WW3224T_W	316L SS WLD	2.00	1.50	.065	.065	5.25	133	●	●	●	●	●		
31WW4816T_W	316L SS WLD	3.00	1.00	.065	.065	11.25	286	●	●	●	●	●		
31WW4824T_W	316L SS WLD	3.00	1.50	.065	.065	9.25	235	●	●	●	●	●		
31WW4832T_W	316L SS WLD	3.00	2.00	.065	.065	7.50	191	●	●	●	●	●		
31WW4840T_W	316L SS WLD	3.00	2.50	.065	.065	5.50	140	●	●	●	●	●		
31WW6416T_W	316L SS WLD	4.00	1.00	.083	.065	15.50	394	●	●	●	●	●		
31WW6424T_W	316L SS WLD	4.00	1.50	.083	.065	13.50	343	●	●	●	●	●		
31WW6432T_W	316L SS WLD	4.00	2.00	.083	.065	11.75	299	●	●	●	●	●		
31WW6440T_W	316L SS WLD	4.00	2.50	.065	.065	9.75	248	●	●	●	●	●		
31WW6448T_W	316L SS WLD	4.00	3.00	.083	.065	7.75	197	●	●	●	●	●		

equal tee
7WWW

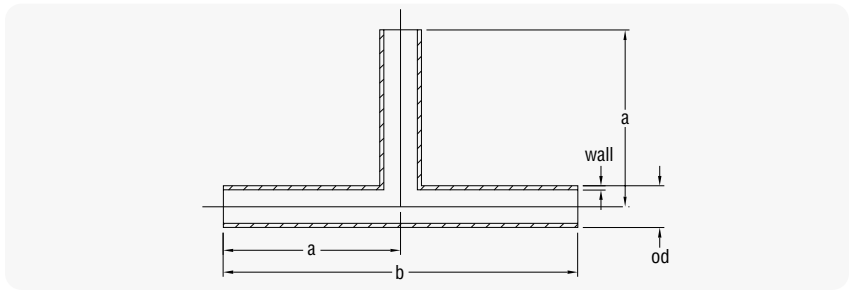

To complete part number add product specification.
Example: 7WWW04T50

part no.	material	dimensions						product specifications						
		od	wall	a	b	a mm	b mm	5	10	20	25	50	100	T622
7WWW04T	316L SS SMLS	.250	.035	1.75	3.50	45	89	●	●	●	●	●	●	
7WWW04TG22	Hastelloy® C22 SMLS	.250	.035	1.75	3.50	45	89							●
7WWW06T	316L SS SMLS	.375	.035	1.75	3.50	45	89	●	●	●	●	●	●	
7WWW06TG22	Hastelloy C22 SMLS	.375	.035	1.75	3.50	45	89							●
7WWW08T	316L SS SMLS	.500	.049	2.12	4.25	54	108	●	●	●	●	●	●	
7WWW08TG22	Hastelloy C22 SMLS	.500	.049	2.12	4.25	54	108							●
7WWW12T	316L SS SMLS	.750	.065	2.12	4.25	54	108	●	●	●	●	●		
7WWW16T_W	316L SS WLD	1.00	.065	2.50	5.00	64	127	●	●	●	●	●		
7WWW16T	316L SS SMLS	1.00	.065	2.50	5.00	64	127	●	●	●	●	●		
7WWW24T_W	316L SS WLD	1.50	.065	2.375	4.75	60	121	●	●	●	●	●		
7WWW24T	316L SS SMLS	1.50	.065	2.375	4.75	60	121	●	●	●	●	●		
7WWW32T_W	316L SS WLD	2.00	.065	2.875	5.75	73	146	●	●	●	●	●		
7WWW32T	316L SS SMLS	2.00	.065	2.875	5.75	73	146	●	●	●	●	●		
7WWW48T_W	316L SS WLD	3.00	.065	3.375	6.75	86	172	●	●	●	●	●		
7WWW64T_W	316L SS WLD	4.00	.083	4.125	8.25	105	210	●	●	●	●	●		

end cap
16W

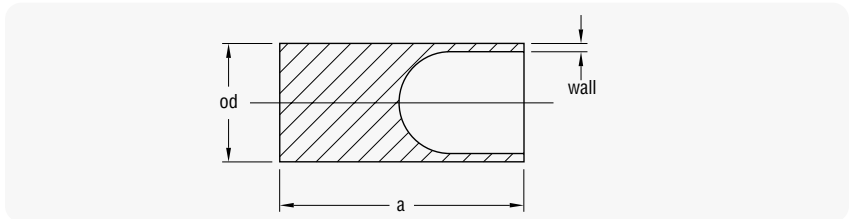

To complete part number add product specification.
Example: 16W04T50

part no.	material	dimensions				product specifications							
		od	wall	a	a mm	5	10	20	25	50	100	T622	
16W04T	316L SS SMLS	.250	.035	1.125	29	●	●	●	●	●	●		
16W04TG22	Hastelloy® C22 SMLS	.250	.035	1.125	29								●
16W06T	316L SS SMLS	.375	.035	1.125	29	●	●	●	●	●	●		
16W06TG22	Hastelloy C22 SMLS	.375	.035	1.125	29								●
16W08T	316L SS SMLS	.500	.049	1.375	35	●	●	●	●	●	●		
16W08TG22	Hastelloy C22 SMLS	.500	.049	1.375	35								●
16W12T	316L SS SMLS	.750	.065	1.75	44	●	●	●	●	●			
16W16T	316L SS SMLS	1.00	.065	1.75	44	●	●	●	●	●			
16W24T	316L SS SMLS	1.50	.065	2.00	51	●	●	●	●	●			
16W32T	316L SS SMLS	2.00	.065	2.00	51	●	●	●	●	●			
16W48T_W	316L SS WLD	3.00	.065	2.00	51	●	●	●	●	●			
16W64T_W	316L SS WLD	4.00	.083	2.50	51	●	●	●	●	●			

Consult factory for availability of other materials, sizes, or wall thickness.

coaxial 90° elbow K2WW

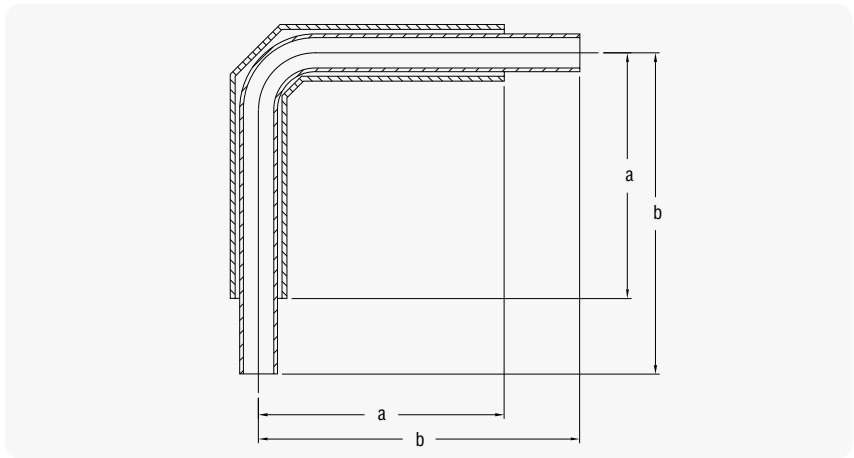

To complete part number add product specification.
Example: X2WW0408T50

part no.	process tube	dimensions									product specifications							
		process od	process wall	contain od	contain wall	a	b	r	a mm	b mm	r mm	5	10	20	25	50	100	T622
X2WW0408T	316L SS SMLS	.250	.035	.500	.049	3.37	4.37	.560	86	111	14	●	●	●	●	●	●	
X2WW0408TG22	Hastelloy® C22 SMLS	.250	.035	.500	.049	3.37	4.37	.560	86	111	14							●
X2WW0610T	316L SS SMLS	.375	.035	.625	.049	3.12	4.12	.560	79	105	14	●	●	●	●	●	●	
X2WW0610TG22	Hastelloy C22 SMLS	.375	.035	.625	.049	3.12	4.12	.560	79	105	14							●
X2WW0812T	316L SS SMLS	.500	.049	.750	.065	3.25	4.25	.750	83	108	19	●	●	●	●	●	●	
X2WW0812TG22	Hastelloy C22 SMLS	.500	.049	.750	.065	3.25	4.25	.750	83	108	19							●
X2WW1216T	316L SS SMLS	.750	.065	1.00	.065	5.00	6.75	1.12	127	172	28	●	●	●	●	●		
X2WW1620T	316L SS SMLS	1.00	.065	1.25	.065	5.37	7.12	1.50	136	181	38	●	●	●	●	●		

coaxial 45° elbow K3WW

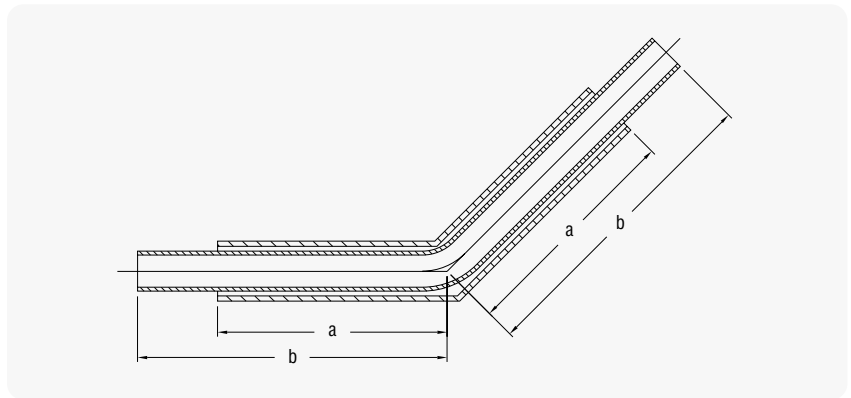

To complete part number add product specification.
Example: X3WW0408T50

part no.	process tube	dimensions									product specifications							
		process od	process wall	contain od	contain wall	a	b	r	a mm	b mm	r mm	5	10	20	25	50	100	T622
X3WW0408T	316L SS SMLS	.250	.035	.500	.049	3.00	4.00	.560	76	102	14	●	●	●	●	●	●	
X3WW0408TG22	Hastelloy® C22 SMLS	.250	.035	.500	.049	3.00	4.00	.560	76	102	14							●
X3WW0610T	316L SS SMLS	.375	.035	.625	.049	2.87	3.87	.560	73	98	14	●	●	●	●	●	●	
X3WW0610TG22	Hastelloy C22 SMLS	.375	.035	.625	.049	2.87	3.87	.560	73	98	14							●
X3WW0812T	316L SS SMLS	.500	.049	.750	.065	2.87	3.87	.750	73	98	19	●	●	●	●	●	●	
X3WW0812TG22	Hastelloy C22 SMLS	.500	.049	.750	.065	2.87	3.87	.750	73	98	19							●
X3WW1216T	316L SS SMLS	.750	.065	1.00	.065	4.37	6.12	1.12	111	155	28	●	●	●	●	●		
X3WW1620T	316L SS SMLS	1.00	.065	1.25	.065	4.50	6.25	1.50	114	159	38	●	●	●	●	●		

coaxial sleeve coupling XSC

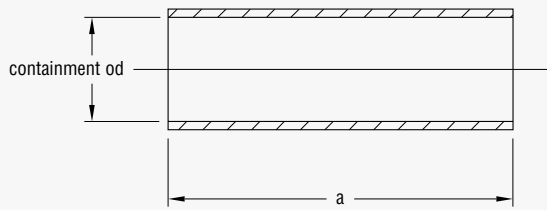

part no.	process tube	dimensions		
		contain od	a	a mm
XSC0408	316L SS SMLS	.500	4.00	102
XSC0610	316L SS SMLS	.625	4.00	102
XSC0812	316L SS SMLS	.750	4.00	102
XSC1216	316L SS SMLS	1.00	4.00	102
XSC1620	316L SS SMLS	1.25	4.00	102

Consult factory for extended lengths.

coaxial termination XTM

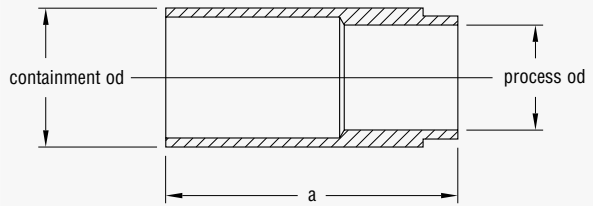

part no.	process tube	dimensions			
		process od	contain od	a	a mm
XTM0408	316L SS SMLS	.250	.500	1.25	32
XTM0610	316L SS SMLS	.375	.625	1.25	32
XTM0812	316L SS SMLS	.500	.750	1.25	32
XTM1216	316L SS SMLS	.750	1.00	2.00	51
XTM1620	316L SS SMLS	1.00	1.25	2.00	51

coaxial starter piece XSP

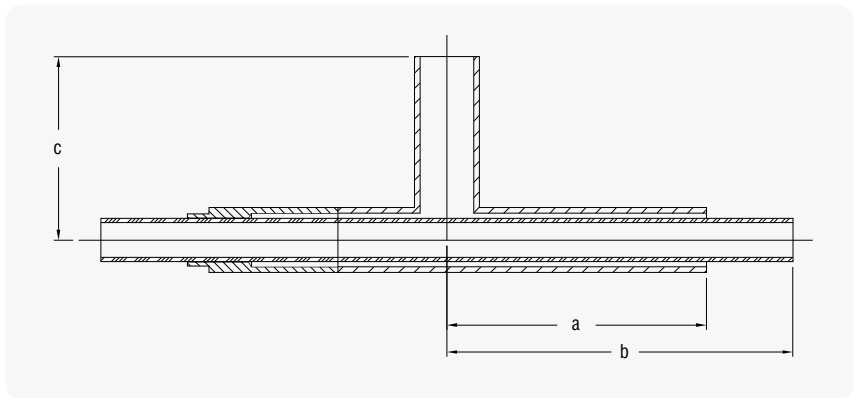

To complete part number add product specification.
Example: XSP0408T50

part no.	process tube	dimensions									product specifications							
		process od	wall	contain od	wall	a	b	c	a mm	b mm	c mm	5	10	20	25	50	100	T622
XSP0408T_	316L SS SMLS	.250	.035	.500	.049	2.87	3.87	2.12	73	98	54	●	●	●	●	●	●	
XSP0408TG22	Hastelloy® C22 SMLS	.250	.035	.500	.049	2.87	3.87	2.12	73	98	54							●
XSP0610T_	316L SS SMLS	.375	.035	.625	.049	3.00	4.00	2.12	76	102	54	●	●	●	●	●	●	
XSP0610TG22	Hastelloy C22 SMLS	.375	.035	.625	.049	3.00	4.00	2.12	76	102	54							●
XSP0812T_	316L SS SMLS	.500	.049	.750	.065	3.00	4.00	2.12	76	102	54	●	●	●	●	●	●	
XSP0812TG22	Hastelloy C22 SMLS	.500	.049	.750	.065	3.00	4.00	2.12	76	102	54							●
XSP1216T_	316L SS SMLS	.750	.065	1.00	.065	4.62	5.62	2.12	117	143	54	●	●	●	●	●		
XSP1620T_	316L SS SMLS	1.00	.065	1.25	.065	4.75	5.75	2.50	121	146	64	●	●	●	●	●		

Consult factory for availability of other materials, sizes, or wall thickness.

coaxial equal tee K7WWW

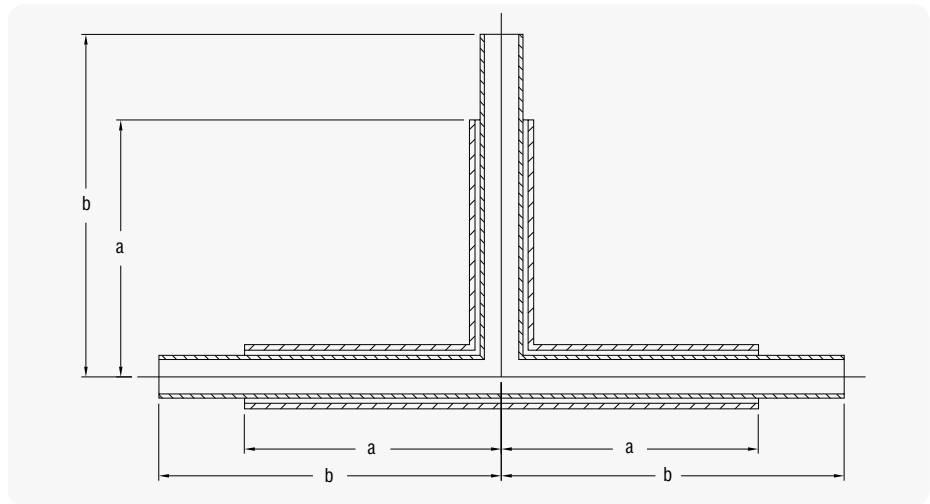

To complete part number add product specification.

Example: X7WWW0408T50

part no.	process tube	dimensions								product specifications						
		process od	wall	contain od	wall	a	b	a mm	b mm	5	10	20	25	50	100	TG22
X7WWW0408T	316L SS SMLS	.250	.035	.500	.049	2.87	3.87	73	98	●	●	●	●	●	●	
X7WWW0408TG22	Hastelloy® C22 SMLS	.250	.035	.500	.049	2.87	3.87	73	98							●
X7WWW0610T	316L SS SMLS	.375	.035	.625	.049	3.00	4.00	76	102	●	●	●	●	●	●	
X7WWW0610TG22	Hastelloy C22 SMLS	.375	.035	.625	.049	3.00	4.00	76	102							●
X7WWW0812T	316L SS SMLS	.500	.049	.750	.065	3.00	4.00	76	102	●	●	●	●	●	●	
X7WWW0812TG22	Hastelloy C22 SMLS	.500	.049	.750	.065	3.00	4.00	76	102							●
X7WWW1216T	316L SS SMLS	.750	.065	1.00	.065	4.62	6.37	117	162	●	●	●	●	●		
X7WWW1620T	316L SS SMLS	1.00	.065	1.25	.065	4.75	6.50	121	165	●	●	●	●	●		

coaxial purge tee KPT

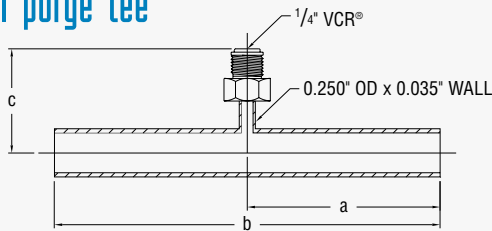

coaxial purge tee w/UCR KPTU

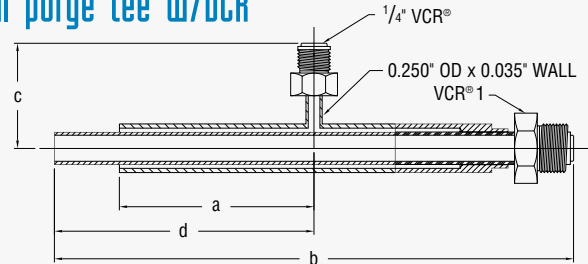

part no.	process tube	dimensions											product specifications							
		process od	containment od	wall	a	b	c	d	a mm	b mm	c mm	d mm	UCR [®] 1	5	10	20	25	50	100	TG22
XPT0408	316L SS SMLS	.250	.500	.049	2.87	5.75	1.51	—	73	146	38	—	—							
XPT0610	316L SS SMLS	.375	.625	.049	3.00	6.00	1.57	—	76	152	40	—	—							
XPT0812	316L SS SMLS	.500	.750	.065	3.00	6.00	1.62	—	76	152	41	—	—							
XPT1216	316L SS SMLS	.750	1.00	.065	4.62	9.25	1.74	—	117	235	44	—	—							
XPT1620	316L SS SMLS	1.00	1.25	.065	4.75	9.50	1.87	—	121	241	48	—	—							
XPTV0408T	316L SS SMLS	.250	.500	.049	2.87	7.75	1.51	3.87	73	197	38	98	.250	●	●	●	●	●	●	●
XPTV0610T	316L SS SMLS	.375	.625	.049	3.00	8.00	1.57	4.00	76	203	40	102	.370	●	●	●	●	●	●	●
XPTV0812T	316L SS SMLS	.500	.750	.065	3.00	8.00	1.62	4.00	76	203	41	102	.500	●	●	●	●	●	●	●
XPTV1216T	316L SS SMLS	.750	1.00	.065	4.62	12.75	1.74	6.37	117	324	44	162	.750	●	●	●	●	●	●	●
XPTV1620T	316L SS SMLS	1.00	1.25	.065	4.75	13.00	1.87	6.50	121	330	48	165	1.00	●	●	●	●	●	●	●

Consult factory for Hastelloy® process tube.

Consult factory for availability of other materials, sizes, or wall thickness.

coaxial reducing tee X7RWWW

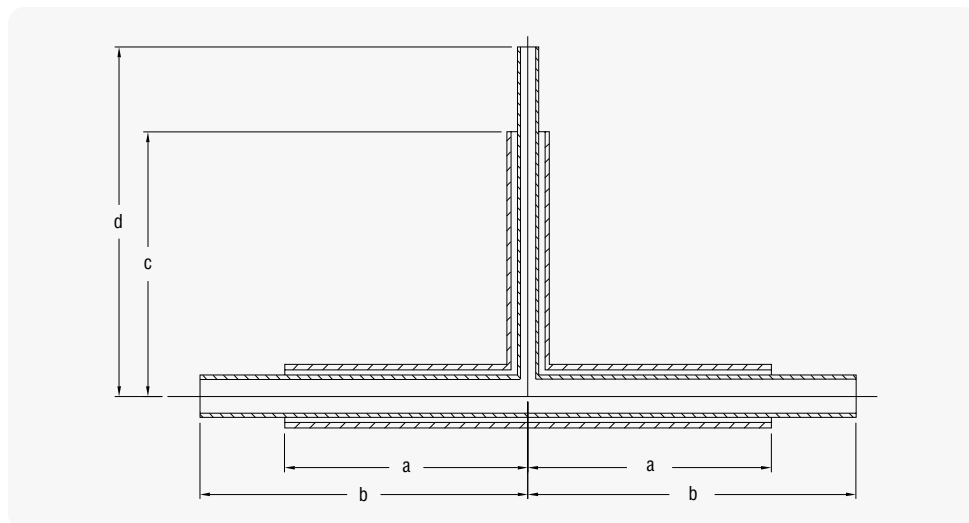

To complete part number add product specification.
Example: X7RWWW0604T50

part no.	process tube	dimensions												product specifications						
		base leg		branch leg		a	b	c	d	a mm	b mm	c mm	d mm	5	10	20	25	50	100	TC22
		process od	contain od	process od	contain od															
X7RWWW0604T	316L SS SMLS	.375	.625	.250	.500	2.87	3.87	3.12	4.12	73	98	79	105	●	●	●	●	●	●	●
X7RWWW0604TG22	Hastelloy® C22 SMLS	.375	.625	.250	.500	2.87	3.87	3.12	4.12	73	98	79	105							●
X7RWWW0804T	316L SS SMLS	.500	.750	.250	.500	2.87	3.87	3.12	4.12	73	98	79	105	●	●	●	●	●	●	●
X7RWWW0804TG22	Hastelloy C22 SMLS	.500	.750	.250	.500	2.87	3.87	3.12	4.12	73	98	79	105							●
X7RWWW0806T	316L SS SMLS	.500	.750	.375	.625	3.00	4.00	3.12	4.12	73	102	79	105	●	●	●	●	●	●	●
X7RWWW0806TG22	Hastelloy C22 SMLS	.500	.750	.375	.625	3.00	4.00	3.12	4.12	73	102	79	105							●
X7RWWW1204T	316L SS SMLS	.750	1.00	.250	.500	4.37	6.12	3.25	4.25	111	155	83	108	●	●	●	●	●	●	●
X7RWWW1206T	316L SS SMLS	.750	1.00	.375	.625	4.50	6.25	3.25	4.25	114	159	83	108	●	●	●	●	●	●	●
X7RWWW1208T	316L SS SMLS	.750	1.00	.500	.750	4.50	6.25	3.25	4.25	114	159	83	108	●	●	●	●	●	●	●
X7RWWW1604T	316L SS SMLS	1.00	1.25	.250	.500	4.37	6.12	3.37	4.37	111	155	86	111	●	●	●	●	●	●	●
X7RWWW1606T	316L SS SMLS	1.00	1.25	.375	.625	4.50	6.25	3.37	4.37	114	159	86	111	●	●	●	●	●	●	●
X7RWWW1608T	316L SS SMLS	1.00	1.25	.500	.750	4.50	6.25	3.37	4.37	114	159	86	111	●	●	●	●	●	●	●
X7RWWW1612T	316L SS SMLS	1.00	1.25	.750	1.00	4.62	6.37	4.87	6.62	117	162	124	168	●	●	●	●	●	●	●

© Hastelloy is a registered trademark of Haynes International.
© VCR is a registered trademark of Swagelok Company.

Consult factory for availability of other materials, sizes, or wall thickness.

product specifications

product specifications

○ tech 5

- Surface roughness of 40 μm / 1.0 μm Ra.
- High quality seamless and welded 316L SS tubing.
- Thermocouple cleaned and capped per ASTM 632 supplement S3.
- Purged with filtered nitrogen, capped and individually bagged in heat sealed polyethylene.
- Used for instrumentation, clean dry air, and other gas systems requiring cleaned high purity tubing.

● tech 10

- Surface roughness of 25 μm / 0.63 μm Ra.
- High quality ASTM 269 and ASTM 270 316L SS tubing.
- Controlled sulfur for consistent weldability.
- Exceeds CFOS CGA G4.1 cleaning.
- Fully passivated with nitric acid.
- Rinsed with DI water, purged with filtered nitrogen, capped and individually bagged in heat sealed polyethylene.
- Used for analyzer sample lines, O₂ piping (CFOS), medical gas distribution and vent lines.

● tech 20

- Chemically polished with a surface roughness of 15 μm / 0.20 μm Ra.
- High quality ASTM 269 and ASTM 270 316L SS tubing.
- Low particulate cleaning.
- Final cleaning and packaging performed in a cleanroom.
- DI water final rinse, purged with filtered nitrogen until dry, capped and individually bagged in heat sealed polyethylene.
- Used for general high purity systems, such as high grade analyzer lines, compressed dry air, argon, nitrogen and other inert bulk gas services.

● tech 25

- Electropolished to 8 μm / 0.20 μm Ra.
- 316L SS tubing meets ASTM specifications for consistent physical, dimensional and chemical composition .
- Controlled sulfur content to insure consistent weldability and reduced non-metallic inclusions.
- Final cleaning and packaging performed in a Class 10 cleanroom.
- Final cleaning performed in a Class 10 cleanroom.
- 0.1 μ filtered 60°C DI water rinse.
- 0.005 μ filtered 120°C Nitrogen dried.
- Ends are sealed by pressing LDPE caps over polyamide nylon film.
- Individually double bagged in heat sealed polyethylene.
- Used in ultra high purity gas, chemical distribution, and WFI systems.



tech 50

- Electropolished to 7 μin / 0.18 $\mu\text{m Ra}$.
- 316L SS tubing meets ASTM specifications for consistent physical, dimensional and chemical composition.
- Restricted sulfur content insures consistent weldability and low non-metallic inclusions.
- Final cleaning and packaging performed in a Class 10 cleanroom.
- 0.1 μ filtered 18 Megohm 60°C DI water rinse until effluent surpasses 17.5 Megohm.
- Dried with 0.005 μ filtered 120°C Nitrogen.
- Ends are sealed by pressing LDPE caps over polyamide nylon film.
- Individually double bagged in heat sealed polyethylene.
- Subjected to numerous quality verification tests including: particle and moisture analysis, SEM, ESCA and Auger.
- Used for ultra high purity gas distribution systems.

tech 100

- Electropolished to 5 μin / 0.13 $\mu\text{m Ra}$ or 10 μin / 0.25 $\mu\text{m Ra}$ surface roughness.
- Produced from secondary remelt 316L SS VAR tubing exceeding ASTM specifications for consistent physical, dimensional and chemical composition.
- Vacuum arc remelt (VAR) material reduces impurities in the stainless steel making it more corrosion resistant and pure than standard 316L SS.
- Restricted sulfur content insures consistent weldability and low non-metallic inclusions.
- Final cleaning and packaging performed in a Class 10 cleanroom.
- 0.1 μ filtered 18 Megohm 60°C DI water rinse until effluent surpasses 17.5 Megohm.
- Dried with 0.005 μ filtered 120°C Nitrogen.
- Ends are sealed by pressing LDPE caps over polyamide nylon film.
- Individually double bagged in heat sealed polyethylene.
- Subjected to numerous quality verification tests including: particle and moisture analysis, SEM, ESCA and Auger.
- Used for ultra high purity specialty gas distribution systems.

TG22

- Hastelloy® C22 – a nickel chromium alloy is extremely resistant to pitting and crevice corrosion.
- Surface roughness of 20 μin / 0.5 $\mu\text{m Ra}$.
- Chemically polished and passivated in nitric acid bath followed by a DI water rinse.
- Final cleaning and packaging performed in a Class 10 cleanroom.
- Rinsed with 0.1 μ filtered 18 Megohm 60°C DI water.
- Dried with 0.005 μ filtered 120°C Nitrogen.
- Ends are sealed by pressing LDPE caps over polyamide nylon film.
- Individually double bagged in heat sealed polyethylene.
- Verified quality by particle and moisture testing.
- Used for high purity distribution of highly corrosive gasses.





www.cardinaluhp.com

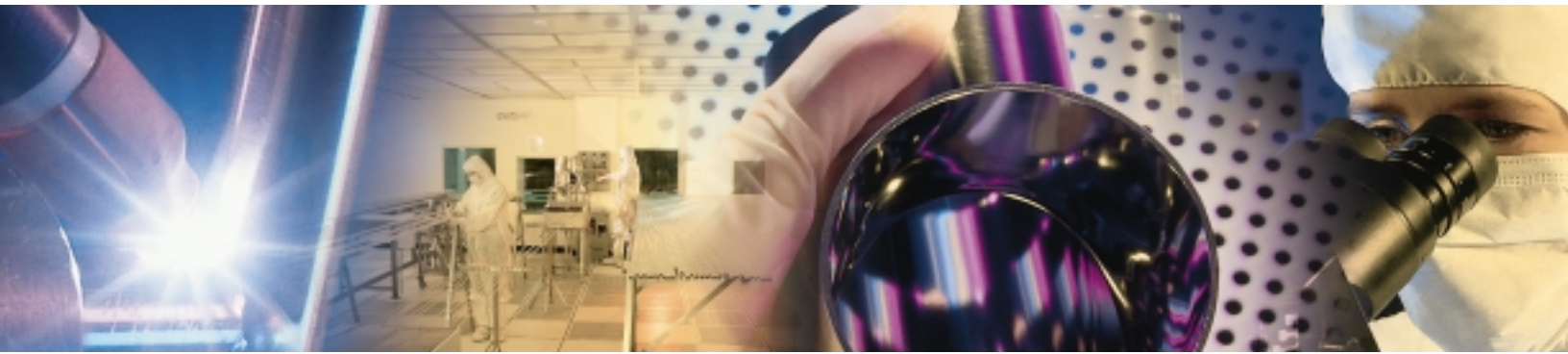

1910 Crystal Industrial Court • Saint Louis, Missouri 63114 • Ph: 314.473.2121 • Fax: 314.473.2120
European Office: Mallekotstraat 65 • B 2500 Lier Belgium • Ph: (+32) 3 491 9875 • Fax: (+32) 3 491 9876

©2001 Cardinal UHP • Bulletin CLT-CRDSPEC • 20 FEB 01

