



ITT

Pure-Flo®

Valve Bodies 2-Way



Engineered for life

www.ittpureflo.com

Pure-Flo Solutions Group has developed a line of valve bodies that help address the needs of the Bioprocessing and Pharmaceutical industries for high quality, welded process systems.

By providing valve bodies with controlled sulfur 316L/1.4435 stainless steel material and weld tangents long enough to accept the most common orbital weld heads in the industry, we have eliminated two of the most common concerns in valve-to-tube welding known today.

Automatic welding of 316L process components is greatly affected by the sulfur content of the mating process components. A disparity of sulfur content can result in reduced orbital weld quality and potentially incomplete fusion of the mating components. By controlling valve body sulfur content to the same chemistry as that required for ASME BPE fittings, welding problems due to material chemistry differences will be greatly reduced.

The Pure-Flo line of valve bodies fully complies with the controlled sulfur requirements for chemical composition of 316L/1.4435 material, set forth by the ASME Bioprocessing Equipment Standard 2002, Table DT-3.

By increasing the valve weld end tangent lengths to the values required for ASME BPE fittings (Table DT-4), we made the valve body compatible with virtually any orbital weld head utilized in the industry. Special offset or narrow heads are no longer required to weld a valve into a process system.

Controlled Sulfur Forging with Extended Weld Tangents

1.00" Valve Extended BW Forging (428L)

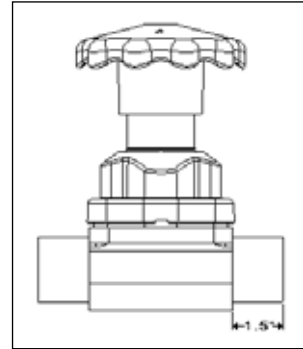

1.00" Valve Short Tangent BW Forging (428)

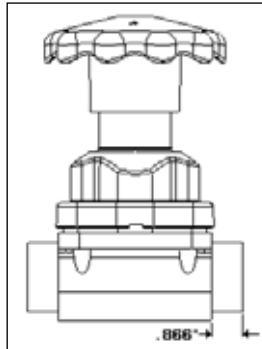

1.00" Valve Short Tangent w/ Tube Extensions (428 + TEB)

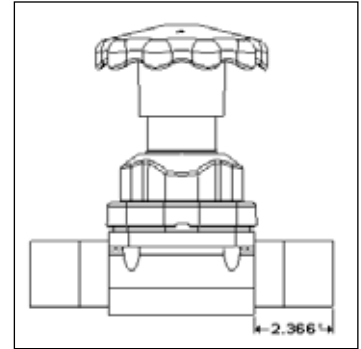

Size	Short Weld Tangent (428)		Extended Weld Tangent* (428L)	Short Over-All-Length (428)	Short Over-All-Length w/1.5" Tube Extensions (428 + TEB)	Extended Over-All-Length (428L)
	IN	DN				
0.50"	DN15	0.748" (19)	1.50" (38)	3.50" (89)	6.50" (165)	5.12" (130)
0.75"	DN20	0.830" (21)	1.50" (38)	4.00" (102)	7.00" (178)	5.50" (140)
1.00"	DN25	0.866" (22)	1.50" (38)	4.50" (114)	7.50" (191)	5.88" (149)
1.50"	DN40	0.866" (22)	1.50" (38)	5.50" (140)	8.50" (216)	7.00" (178)
2.00"	DN50	0.984" (25)	1.50" (38)	6.25" (159)	9.25" (235)	7.62" (194)
2.50"	DN65	1.162" (29.5)	1.75" (44.5) ¹	8.75" (222)	11.75" (298)	10.00" (254)
3.00"	DN80	1.162" (29.5)	1.75" (44.5)	8.75" (222)	11.75" (298)	10.00" (254)
4.00"	DN100	1.250" (32)	2.00" (51)	11.50" (292)	14.50" (368)	13.00" (330)

*Meets or exceeds ASME BPE Table DT-4 for fitting weld tangents.

¹Exceeds ASME BPE requirements.

316L Sulfur Controlled Chemistry per ASME BPE Table DT-3	
Element	%
Carbon (C)	0.035 max
Silicon (Si)	.75 max
Manganese (Mn)	2.0 max
Nickel (Ni)	10 - 15
Chromium (Cr)	16 - 18
Molybdenum (Mo)	2.0 - 3.0
Phosphorous (P)	0.04 max
Sulfur (S)	0.005-0.017 max

Fitting Weld Tangents per ASME BPE Table DT-4		
IN	DN	Size
0.5"	DN15	1.5" (38)
0.75"	DN20	1.5" (38)
1.0"	DN25	1.5" (38)
1.5"	DN40	1.5" (38)
2.0"	DN50	1.5" (38)
2.5"	DN65	1.5" (38)
3.0"	DN80	1.75" (44.5)
4.0"	DN100	2" (51)



Additional Benefits of the new Pure-Flo Body:

- No welded tube extensions required for most welding equipment
- Less over-all valve body length compared to welded tube extensions
- Fewer welds in the process system
- Less validation paperwork due to fewer material certifications
- Higher quality field welds
- No narrow or off-set weld heads required.

All these benefits add up to lower installation costs and improved production schedules.

End Connections

Pure-Flo Diaphragm Valve bodies are available in a variety of end connections:

- Tri-Clover Tri-Clamp®
- Cherry Burrell "S", "Q" and "I" line®
- 14, 16, 18, 20 O.D. Gauge Tubing
- Schedule 5, 10, 40 Piping
- ISO Ends
- SMS 1146 Ends
- DIN 11850 Ends

Body Dimension Charts

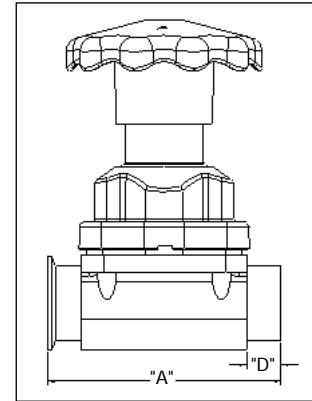
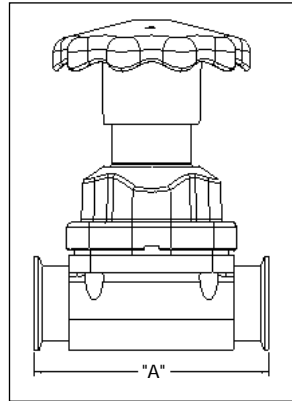
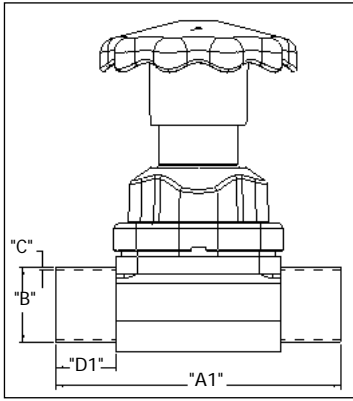

Body Dimension Charts US & SMS

USOD (ANSI) Forgings & Castings										SMS	
B End Connection Size		A Overall Length	D Weld Tangent	A1 Overall Length	D1 Weld Tangent	C				B	C
IN	DN	Tri Clamp, TC x BW, Short Tangent BW	Short Tangent BW, TC x BW	Extended BW Forging	Extended BW Forging	20 GA. 0.035"	18 GA. 0.049"	16 GA. 0.065"	14 GA. 0.083"	BW Forging	BW Forging
Forgings											
BT 1/4"	DN6	3.5" (89)**	1" (25)**	N/A	N/A	S	O				
BT 3/8"	DN10	3.5" (89)**	1" (25)**	N/A	N/A	S	O				
BT 1/2"	DN15	3.5" (89)**	1" (25)**	N/A	N/A			O	S		
1/2"	DN15	3.5" (89)	0.748" (19)	5.12" (130)	1.5" (38)	O	O	S	O		
3/4"	DN20	4" (102)	0.83" (21)	5.5" (140)	1.5" (38)	O	O	S	O		
1"	DN25	4.5" (114)	0.866" (22)	5.88" (149)	1.5" (38)			O	S	O	(25) (1.2)
1.5"	DN40	5.5" (140)	0.866" (22)	7" (178)	1.5" (38)		O	S	O	O	(38) (1.2)
2"	DN50	6.25" (159)	0.984" (25)	7.62" (194)	1.5" (38)			S	O	O	(51) (1.2)
2.5" *	DN65	8.75" (222)	1.162" (29.5)	10" (254)	1.75" (44.5)			S	O	O	(63.5) (1.6)
3"	DN80	8.75" (222)	1.162" (29.5)	10" (254)	1.75" (44.5)			S	O	O	(76.1) (2)
4"	DN100	11.5" (292)	1.25" (32)	13" (330)	2.0" (51)			O	S		
Castings											
1/2"	DN15	3.5" (89)	0.5" (13)	N/A	N/A	O	O	S	O		
3/4"	DN20	4" (102)	0.5" (13)	N/A	N/A	O	O	S	O		
1"	DN25	4.5" (114)	0.5" (13)	N/A	N/A		O	S	O	(25)	(1.2)
1.5"	DN40	5.5" (140)	0.5" (13)	N/A	N/A		O	S	O	(38)	(1.2)
2"	DN50	6.25" (159)	0.5" (13)	N/A	N/A			S	O	(51)	(1.2)
2.5"	DN65	7.62" (194)	0.5" (13)	N/A	N/A			S	O	(63.5)	(1.6)
3"	DN80	8.75" (222)	0.62" (16)	N/A	N/A			S	O	(76.1)	(2)
4"	DN100	11.5" (292)	0.62" (16)	N/A	N/A			O	S		

* 2.5" size uses 3" topworks

**BT TC x BW and TC x TC bodies are 2.5" (64) overall length with 0.5" (13) tangent

Note: Extended Weld Tangents are available only with USOD (ANSI) end connections

Dimensions in () are mm; S = Standard; O = Optional; BT = Bio-Tek Body

ISO/DIN Castings & Forgings

ISO/DIN Castings & Forgings																	
		ISO										DIN Series 1		DIN Series 2		DIN Series 3	
End Connection Size DN	Topworks Size	A	D	B	C							B	C	B	C	B	C
		mm	mm	mm	1	1.2	1.6	2	2.3	2.6	2.9	mm	mm	mm	mm	mm	mm
DN6	BIOTEK	89	25	8	S	O						8	1				
DN10	BIOTEK	89	25	13.5	O		S	O				10	1				
DN15	BIOTEK	89	25	17.2	O		S	O				12	1	13	1.5	14	2
DN15	1/2"	106	25	21.3			S	O				18	1	19	1.5	20	2
DN20	3/4"	118	25	26.9			S	O				22	1	23	1.5	24	2
DN25	1"	127	25	33.7			O	S				28	1	29	1.5	30	2
DN40	1 1/2"	174	35	48.3			O	S				40	1	41	1.5	42	2
DN50	2"	191	35	60.3				S	O	O	Cast Only	52	1	53	1.5	54	2
DN65	3"	229	35	76.1				O	S	O		70	2				
DN80	3"	229	35	88.9					S	O		85	2				
DN100	4"	292	31	114.3					S	O		104	2				

Note: All measurements are mm unless otherwise noted.

S = Standard; O = Optional

Drain Angles

Valve Size		Forging			Investment Casting	
		ANSI	ISO	DIN	ANSI	ISO
Inch	DN	ANSI	ISO	DIN	ANSI	ISO
1/4, 3/8, 1/2 ¹	6, 10, 15 ¹	30°/20° ²	20°	20°	N/A	N/A
0.50	15	30°	13°	16°	30°	17°
0.75	20	30°	21°	25°	30°	18°
1.00	25	30°	22°	26°	31°	20°
1.50	40	28°	17°	22°	30°	20°
2.00	50	23°	16°	19°	25°	19°
2.50	65 ⁵	26° ^{3,6}	23°	23°	19°	N/A
3.00	80 ⁵	20° ⁶	14°	18°	25°	N/A
4.00 ⁴	100 ⁵	16°	11°	14°	20°	N/A
6.00	150	N/A	N/A	N/A	20°	N/A

¹ Bio-Tek sizes.

² 20° is drain angle for the Bio-Tek butt weld bodies with 1" (25.4 mm) cut-backs. 30° is drain angle for Bio-Tek TC bodies. Consult engineering drawings for drain angles on Bio-Tek fabrications.

³ 3" forge body with 2 1/2" end connection.

⁴ 4" ANSI body is wrought/forgings to be available 8/04.

⁵ 4" ANSI body is wrought/forgings to be available 8/04.

⁶ DN 65, 80, 100 bodies to DIN/ISO dimensions are wrought.

⁶ Drain angles for 2.5" and 3.00" Extended tangent forgings have not been determined. Contact factory for details.

Note: As a rule of thumb drain angle tolerances of +/- 2° will assure optimal drainability. Consult Pure-Flo product engineering for specific drain angle tolerances.

Drainability

Drain marks are provided as standard on cast and forged bodies to facilitate installation and optimize drainability. One mark must be located in the vertical plane, cutting the centerline of the pipe.

The slope of process piping must be designed to provide proper pitch in order to optimize drainability. Drainability in a process system is ultimately the responsibility of the system designer end user.

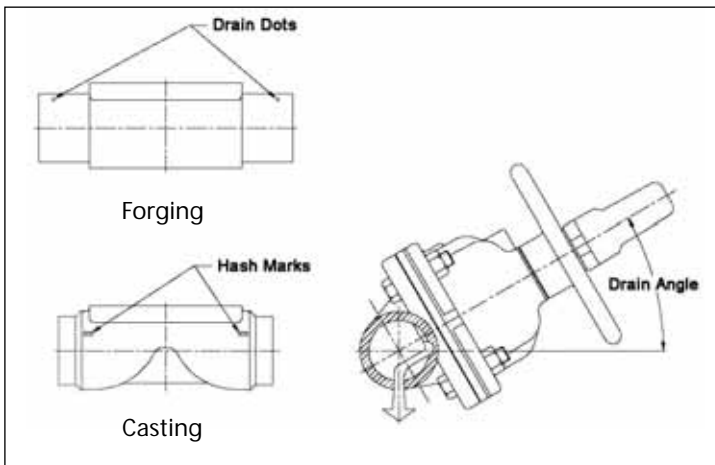

Metallurgy

Pure-Flo Solutions Group customers have a choice of valve body types based on the needs and requirements of the process application. Pure-Flo standard body material for forged bodies is 316L, 1.4435 sulfur controlled to ASME BPE 2002 Table DT-3.

Wrought bodies are available in 316L, 1.4435 or other special materials. Biopharmaceutical applications may require special alloys or materials to provide a desired performance. Consult a Pure-Flo Solutions Group representative for availability and application information.

All valve bodies are fully material heat traceable to EN 10204 3.1B. Certified Mill Test Reports are provided as standard.

Surface Finish

Pure-Flo valve bodies are available in a complete range of mechanically polished and electropolished internal surface finishes to satisfy system design requirements.

Pure-Flo valves are available in a complete range of ASME BPE compliant internal surface finishes.

Pure-Flo Solutions Group provides a complete range of both internal and external electropolish options. Electropolish surface finishing creates a superior surface finish for biopharmaceutical applications. Electropolishing improves corrosion resistance, removes inclusions and contaminants, and improves the over-all surface for cleaning and sterilization.

Metallurgy

		Forged	Wrought	Cast
Size Range	ANSI	1/2" - 4"	1/2" - 6"	1/2" - 6"
	DIN/ISO	DN 15 - DN50	DN 15 - DN150	DN 15 - DN50
316L Stainless Alloy		Tri Certified to ASTM A182 Grade 316L, S9, DIN 17440, 1.4435, BN2	ASTM A479, A240, 316L DIN 17440, 1.4435, BN2	ASTM A351 Grade CF 3M
Special Alloys*			C22, C276, AL6XN	
Dimensional Standards		USOD Tubing, Pipe, ISO/DIN/SMS	USOD Tubing, Pipe, ISO/DIN	USOD Tubing, Pipe, ISO/DIN
Ferrite content		< 0.5%	< 3%	< 12%

* other materials available upon request

Surface Finish

Mechanical Polish Surface Finish (Interior Only)		
Code	Non-EU Service Microinch Max	EU Service Micron Max
0	NO MECHANICAL POLISH	NO MECHANICAL POLISH
2	35 Ra	0.8 Ra
6	25 Ra	0.6 Ra
8	20 Ra	0.5 Ra
7	15 Ra	0.4 Ra
9	11 Ra	0.3 Ra

Electropolish Surface Finish (Interior & Exterior)	
Code	
0	NO ELECTROPOLISH
2	EXTERIOR ELECTROPOLISH ONLY
3	BOTH INTERIOR AND EXTERIOR ELECTROPOLISH
4	INTERIOR ELECTROPOLISH ONLY

Surface Finishes per ASME BPE 2002*	
Code	Mechanical Polished Surface Finish (Interior Only)
	Microinch MAX
SFV1	20 Ra
SFV2	25 Ra
SFV3	30 Ra
	Mechanical Polished & Electropolished Surface Finish (Interior Only)
	Microinch MAX
SFV4	15 Ra
SFV5	20 Ra
SFV6	25 Ra

*ASME BPE 2002 Addenda 2004

Marking

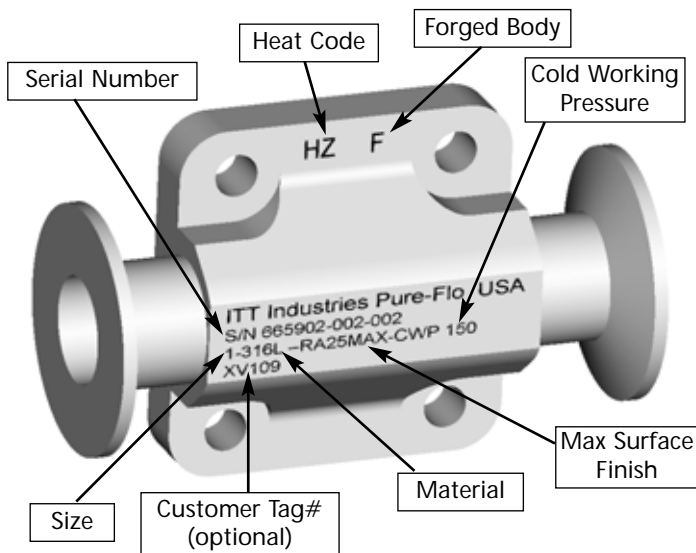

Marking for European Union Service

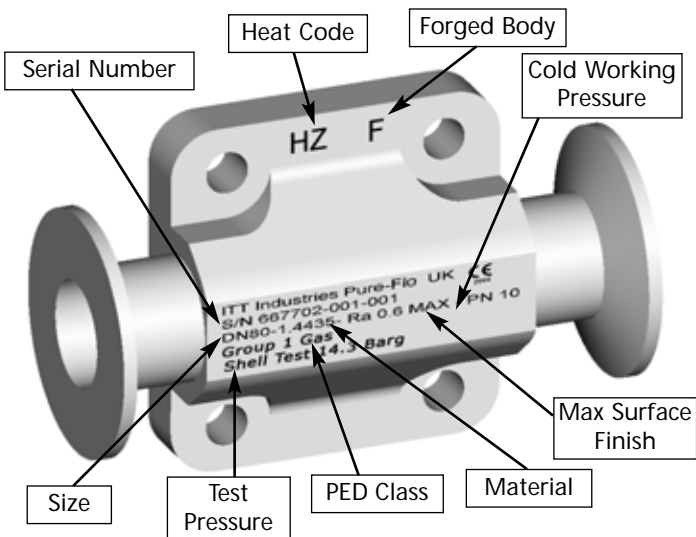

Pure-Flo valves comply with the European Union (EU) Pressure Equipment Directive (PED) 97/23/EC Category 1. Valve bodies are CE marked per the 97/23/EC when EU service is requested.

Validation

Pure-Flo Solutions Group provides critical validation information to meet the needs of the Pharmaceutical and Bioprocessing industries.

Marking

Pure-Flo valve bodies are marked directly on the valve body, typically on the bottom of the valve or underside of the bonnet flange. Separate, attached stainless steel tags have been eliminated, where possible, except for limited cases such as special marking requirements and fabrications that prohibit direct body marking. Additional information such as customer tag number is available upon request.

Certified Mill Tests Reports

All Pure-Flo Valve bodies contain a heat number traceable per EN 10204 3.1B. Certified Mill Test Reports (CMTRS) are provided as standard on all Pure-Flo valves.

Certificate of Compliance to Specifications

A Certificate of Compliance to customer specification is provided as a standard on all Pure-Flo valves.

Additional Validation information available on request

- Interior Surface Characterization documentation
- Certification of compliance to CFR Title #21 section 177
- Certification to USP XXIII Class VI compliance and/or physical testing document
- Quality assurance manual
- ISO 9001 certification
- Certification of testing to MSS-SP-88

For more information, please contact:

Pure-Flo Headquarters

33 Centerville Road
Lancaster, PA 17603-2064 USA
Phone +1 (800) 787-3561
Phone +1 (717) 509-2200
Fax +1 (800) 239-9402

Website: www.ittpureflo.com
E-mail: pureflo.custserv@itt.com

Valve Office Locations:

Pure-Flo
110-B West Cochran
Simi Valley, CA 93065 USA
Phone +1 (800) 926-8884
Phone +1 (805) 520-7200
Fax +1 (805) 520-7205

Pure-Flo
Richards Street
Kirkham, Lancashire
PR4 2HU, England
Phone +44-1772-682696
Fax +44-1772-686006

Other Locations:

Pure-Flo
9625 55th Street
Kenosha, WI 53144 USA
Phone +1 (262) 654-6466
Fax +1 (262) 658-0694

